

BY GILCO

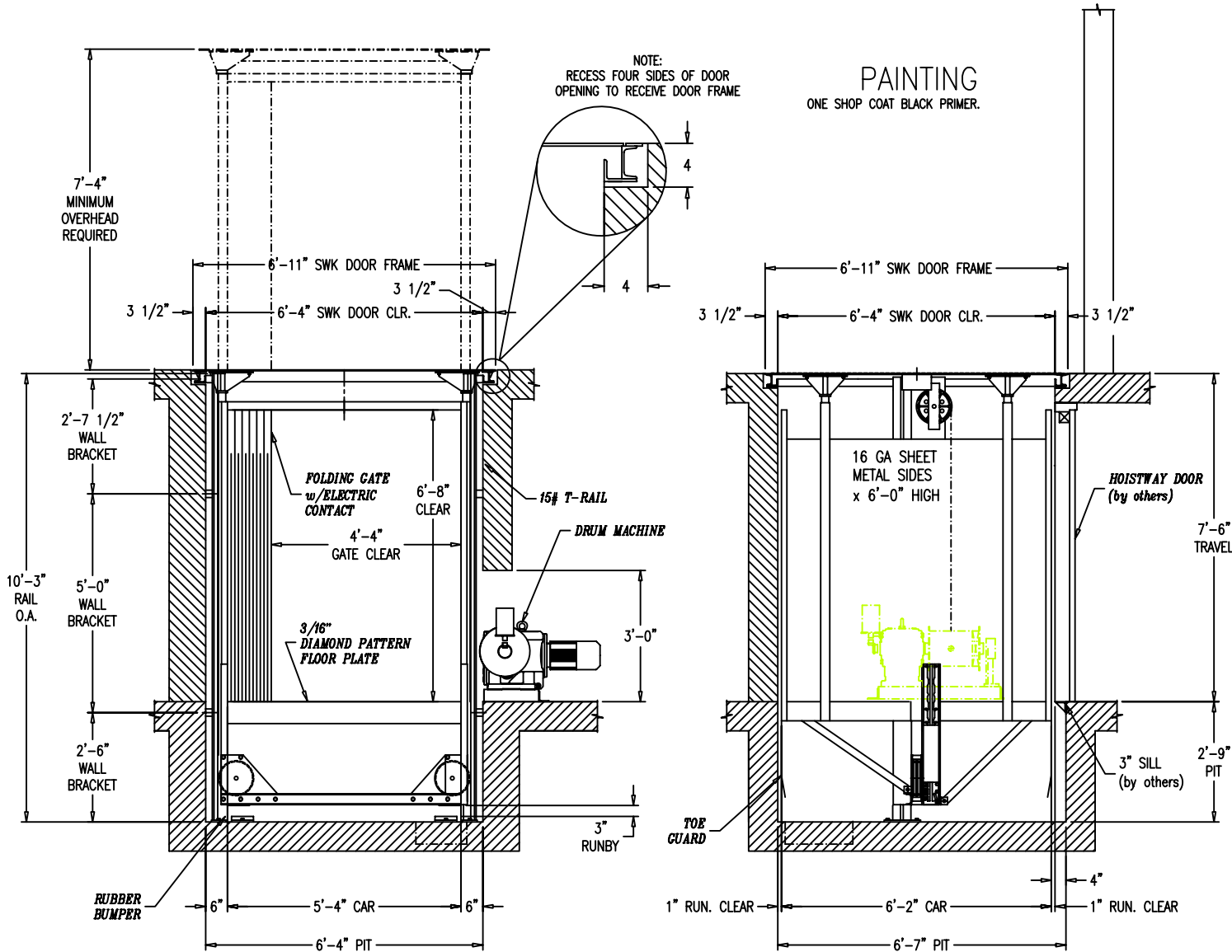

**PAINTING**  
ONE SHOP COAT BLACK PRIMER.

NOTE:  
RECESS FOUR SIDES OF DOOR  
OPENING TO RECEIVE DOOR FRAME

CONTROLLER: CONSTANT PRESSURE, NEMA 1 ENCLOSURE  
POTENTIAL SWITCH.  
MAGNETIC REVERSING SWITCH WITH (3) THERMAL OVERLOAD RELAYS.  
VOLT CONTROL CIRCUIT TRANSFORMER.

WEATHER TIGHT KEY OPERATED CONSTANT PRESSURE CONTROL STATION  
(UP, DOWN, IN-USE LIGHT) AT UPPER LEVEL.  
UPPER & LOWER NORMAL LIMIT SWITCHES.  
FINAL UPPER & LOWER MACHINE SCREW LIMIT SWITCH.  
DRUM SLACK CABLE SWITCH.  
EMERGENCY OFF SWITCH ON CAR.  
(2) FOLDING GATES W/ ELECTRIC CONTACT.  
3/16" DIAMOND PATTERN FLOOR PLATE.  
16 GA SIDES x 6'-0" HIGH.  
TOE GUARDS.  
INSTANTANEOUS WEDGE TYPE BROKEN ROPE SAFETY.  
10" DIA. SHEAVES WITH OILITE IMPREGNATED BRONZE BEARINGS.  
10" DIA. DOUBLE GROOVED STEEL DRUM.  
(2) 3/8" WIRE ROPE PRE FORMED PLOW STEEL CABLES.  
15# T-RAILS & ACCESSORIES.  
(2) RUBBER BUFFERS.  
VIBRATION ISOLATION PADS UNDER MACHINE AT ANCHOR POINTS.

BY OTHERS

PROVIDE ELECTRIC POWER TERMINATED IN FUSED DISCONNECT SWITCH.  
SETTING OF SIDEWALK DOOR AND PIPING OF DRAIN.  
FINISH PAINTING.  
SHAFTWAY WIRING, CONDUIT, TRAVELING CABLE TO CAR.  
HOISTWAY DOOR & DOOR INTERLOCK.

MODEL PS1E-1	
SERVICE LIFT	
DUTY(lbs)	2000
SPEED(fpm)	20
MOTOR:	squirrel cage high torque
H.P.	5
RPM:	
VOLTAGE:	208/3/60
REDUCER:	HELICAL BEVEL
GILLESPIE CORPORATION	
WARE, MASSACHUSETTS	
BUILDING:	
LOCATION:	
ARCHITECT:	
INSTALLER:	
ENGINEER YM	DATE
CHECK	FILE NAME 8815-1R2.dwg
SO NO 8815	SHEET 1 OF 2

SECTION A

SECTION B

**EXAMPLE ONLY – SECTION 14440**

**ELECTRIC SIDEWALK ELEVATOR**

**PART 1 - GENERAL**

**1.01 WORK INCLUDED**

- A. Provide electric drum machine operated sidewalk elevator system designed per ANSI/ASME A17.1 Safety Code for Elevators and Escalators, complete with drum machine, all safety devices, car frame and platform, cab and gates, bow irons, guide rails, rail brackets, pit bumpers, shaftway switches, control station, deflecting sheaves, cable equalizer, roping and attachment hardware, hardware and accessories as required.
- B. Provide sidewalk door designed per code for 300 PSF loading.
- C. Provide fire rated lower landing door including frames, sill, vision panel, electro-mechanical interlock, and all required hardware.
- D. Review construction documents to assure necessary spaces and materials for legal sidewalk elevator service are being provided under other sections.
  - 1. Ensure that proper fused disconnect switches, hoistway, pits, and machinery room with access, lighting, and services are being provided under other section.
  - 2. Inform Architect of any discrepancies or omissions prior to final pricing.
  - 3. Work of this Section includes furnishing items necessary for a complete operational sidewalk elevator system and not provided elsewhere.

**1.02 RELATED WORK**

- A. Hoistway construction, if required.
- B. Pit drainage, if required.
- C. Electrical power to Machine Room, including main switch, breaker and lighting.

**1.03 QUALITY ASSURANCE**

- A. Sidewalk Elevator Design Requirements: Provide complete operational drum machine operated sidewalk elevator conforming with Contract Documents and applicable codes and standards.
  - 1. Type: Gillespie Corporation model PS1E.
  - 2. Net Capacity: TBD LBS., Class A loading (hand truck with load).
  - 3. Speed: 20 – 25 FPM.
  - 4. Stops: Two opposite.
  - 5. Travel: Nominal 0' 0". (PLEASE SPECIFY ALL DATA BELOW)
  - 6. Platform Size: 0'-0" x 0'-0".
  - 7. Hoistway size: 0'-0" x 0'-0", pit depth 0'-0" available.
  - 8. Lower landing Door Size: 0'-0" x 0'-0" nominal.

9. Operation: Constant pressure key switch from upper sidewalk landing, with an in-use light.
10. Bows: One required with light.
11. Power: TBD volt, 3 phase minimum for TBD HP motor.

#### **1.04 REFERENCES**

- A. ANSI A17.1: Safety Code for Elevators and Escalators.
- B. ANSI C1/NFPA 70: National Electrical Code.
- C. ANSI A17.1: Inspectors Manual for Electric Elevators.
- D. AWS D1.1: Structural Welding Code.

#### **1.05 SUBMITTALS** - Submit the following

- A. Shop Drawings per Code: Indicate space requirements, general arrangement of equipment, and material being supplied.
- B. Product Data: Submit descriptive brochures, literature, or approved drawings from past jobs of similar design.

#### **1.06 DELIVERY, STORAGE AND HANDLING**

- A. Deliver items and materials to site only after area in which they are to be installed is ready to receive them in their place of final installation.
- B. Store materials in storage area allotted.
- C. Fully protect movable and operating equipment from weather.

#### **1.07 WARRANTY**

- A. Provide coincidental product warranties, where available, for major components of sidewalk elevator work.

### ***PART 2 - PRODUCTS***

#### **2.01 ACCEPTABLE MANUFACTURERS**

- A. Gillespie Corporation (34 Pine Street, Ware, MA 01082; T: 413/967-4980; F: 413/967-9534; E: [sales@gillespiecorp.com](mailto:sales@gillespiecorp.com); W: [www.gillespiecorp.com](http://www.gillespiecorp.com)).
- B. Substitutions must be approved by architect, and must meet all design requirements.

## 2.02 MATERIALS

- A. Elevator frame, hardware, and sidewalk door to be built from structural A36 steel. Electrical controls, switches, and wiring must meet all referenced codes and local and national building codes.

## 2.03 FABRICATION

- A. Electric sidewalk elevator: Electric sidewalk elevator designed for Class A freight loading, conforming with requirements of ANSI/ASME A17.1. Frame and platform to be constructed of structural A36 steel.
- B. Lifting Machine: Machine to be comprised of electric motor, electric or mechanical brake, gear reducer, double grooved drum with flanges, steel keyed shaft, shaft end support bearing, slack cable device with reset switch, screw limit switch, structural steel base, and steel pit strap. Double grooved drum for two wire ropes of minimum 3/8" diameter. Drum to have at least two dead wraps remaining when elevator is at lowest landing.
  - 1. HP: Minimum TBD horsepower, voltage TBD minimum.
- C. Suspension: Two 0" diameter steel wire ropes properly connected to drum, with overhead double grooved shaftway deflecting sheaves securely fastened to top of guide rails and sidewalk door frame, and overhead mechanical cable equalizer securely fastened to top of guide rails and sidewalk door frame, with reset slack cable switch.
- D. Frame and Safeties: Structural steel car frame with channel stiles, properly braced to car platform. Two double grooved undercar deflecting sheaves for 2:1 roped underslung frame design, with sintered bronze oilite bushings. Instantaneous Type A safeties to be activated by a lack of suspension means.
- E. Cab and Platform: Manufacturer's standard structural steel construction: minimum 3/16" diamond plate platform floor. Provide 6'-0" high 16 ga. steel wall panels reinforced with steel angles, steel scissors type "Lazy Tong" folding gates front and rear with 3'-0"x6'-8" clear opening, one bow light, and emergency off switch on side panel.
- F. Sidewalk Doors: Complete weatherresistant assembly with recessed preformed gutters, non-ferrous bronze hinges, and pipe connections for piping to drain. Door plates to be designed for 300 PSF per Code. Finish to be 1/4" non-slip diamond plate.
- G. Lower Landing Door: 1 1/2 hr UL "B" labeled fire rated steel hollow metal single-swing door prefitted with latch, closer, vision panel, and electro-mechanical interlock.
- H. Operating Controller and Shaftway Switches: Manufacturer's standard relay logic controller with steel enclosure, and weatherresistant normal and final shaftway limit switches conforming with referenced codes.
- I. Miscellaneous Items: Rails, rail brackets, bumpers, anchors, pit ladder, pit switch, and items as required by applicable codes and as required for complete operational system.

## **2.04 FINISHES**

### **A. Nonexposed-to-view Surfaces:**

1. Structural and nonexposed Ferrous Metal Surfaces: Clean surfaces of rust, oil or grease and prime with structural steel primer.
2. Field Welds: Remove oxidation, flux or residue, wire brush clean, apply two coats of primer.

### **B. Exposed-to-view Surfaces: Clean, degrease metal surface; apply black primer; semi-gloss enamel applied in field; color as approved by Architect.**

## ***PART 3 - EXECUTION***

### **3.01 PREPARATION**

- A. Examine work of other trades on which sidewalk elevator work depends. Report defects to Architect in writing which may affect elevator work or equipment operation.
- B. Ensure shafts and openings for moving equipment are plumb, level and in line and that pit is to proper depth, waterproofed and drained, with ladder and guards.
- C. Ensure machine room is properly illuminated, heated, and ventilated. Provide hoistway access in machine room wall for drum machine placement, per contract drawings.
- D. Before fabrication, take necessary job site measurements and verify where work is governed by other trades; check measurement of space for equipment and means of access for installation and operation.
  1. Obtain dimensions from site for preparation of shop drawings.
- E. Ensure preparatory work has been properly completed to receive elevator work, including such work as:
  1. Electrical feeder wires are provided to fused disconnect switch in machine room.
  2. Hoistway outlets and power are provided for car light and for light in pit and light and outlets in machine room.
  3. Electric power is available for testing and adjusting equipment.
  4. Machine room is enclosed and protected from moisture, with lockable door.
- F. Supply in ample time for installation by other trades, inserts, anchors, bearing plates, brackets, supports and bracing, including setting templates and diagrams for placement.

### **3.02 INSTALLATION**

- A. Perform work with mechanics skilled in this work and under direct control and supervision of elevator installer's experienced foreman. Installer to be approved by manufacturer, and have experience in installing sidewalk elevators.
- B. Set door in alignment with car opening and true with plumb sill lines; sidewalk doors set flush when closed.

- C. Install in accordance with manufacturer's instructions, applicable codes, and standards to provide a quiet, smoothly operating installation, free from sidesway, oscillation or vibration.
- D. Mount machine in accordance with approved shop drawings; isolate and dampen machine vibration with properly sized sound-reducing anti-vibration rubber pads. Connect terminal rope sockets using approved techniques.
- E. Grout sills and sidewalk door frames per manufacturers instructions.
- F. Locate and mount sidewalk level control station per manufacturers instructions.
- G. Supply all equipment necessary for installation not provided by elevator manufacturer; including hoistway wiring and waterproof conduit, rail bracket wall anchors or inserts, and finish painting. Some work, such as casting of inserts should be done by contractor or subcontractor.

### **3.03 INSPECTION**

- A. Obtain and pay for necessary inspections and permits and make such tests as are required by regulations and authorities.
- B. Final inspection shall be after elevator installation, hoisting enclosure and machine room are complete.
- C. Inspect installation in accordance with ANSI A17.2.
- D. Deliver test certificates and permits to Architect.

### **3.04 MAINTENANCE**

- A. Maintain entire sidewalk elevator installation 12 months after date of Substantial Completion of Work.
- B. Include systematic examination, adjustment and lubrication of elevator equipment.
- C. Extended Maintenance Proposal: Submit proposal for maintenance of installed elevator work for a period of three years after termination of regular maintenance required at end of this section.
  - 1. Proposal shall include stipulated sum for time period stated, with premiums due annually.
  - 2. Extended maintenance proposal shall include requirements specified at end of section for first year maintenance agreement.
  - 3. Repair or replace worn electrical and mechanical parts of elevator equipment, using parts produced by manufacturer of equipment.
- D. Provide 24 hour emergency call-back service during maintenance period.
- E. Ensure competent personnel handle maintenance service; maintain locally an adequate stock of parts for replacement or emergency purposes.

**END OF SECTION**

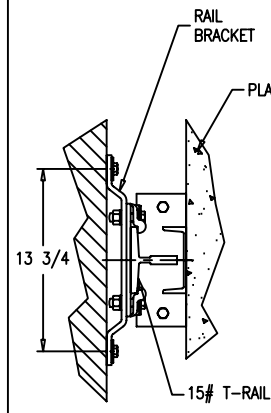
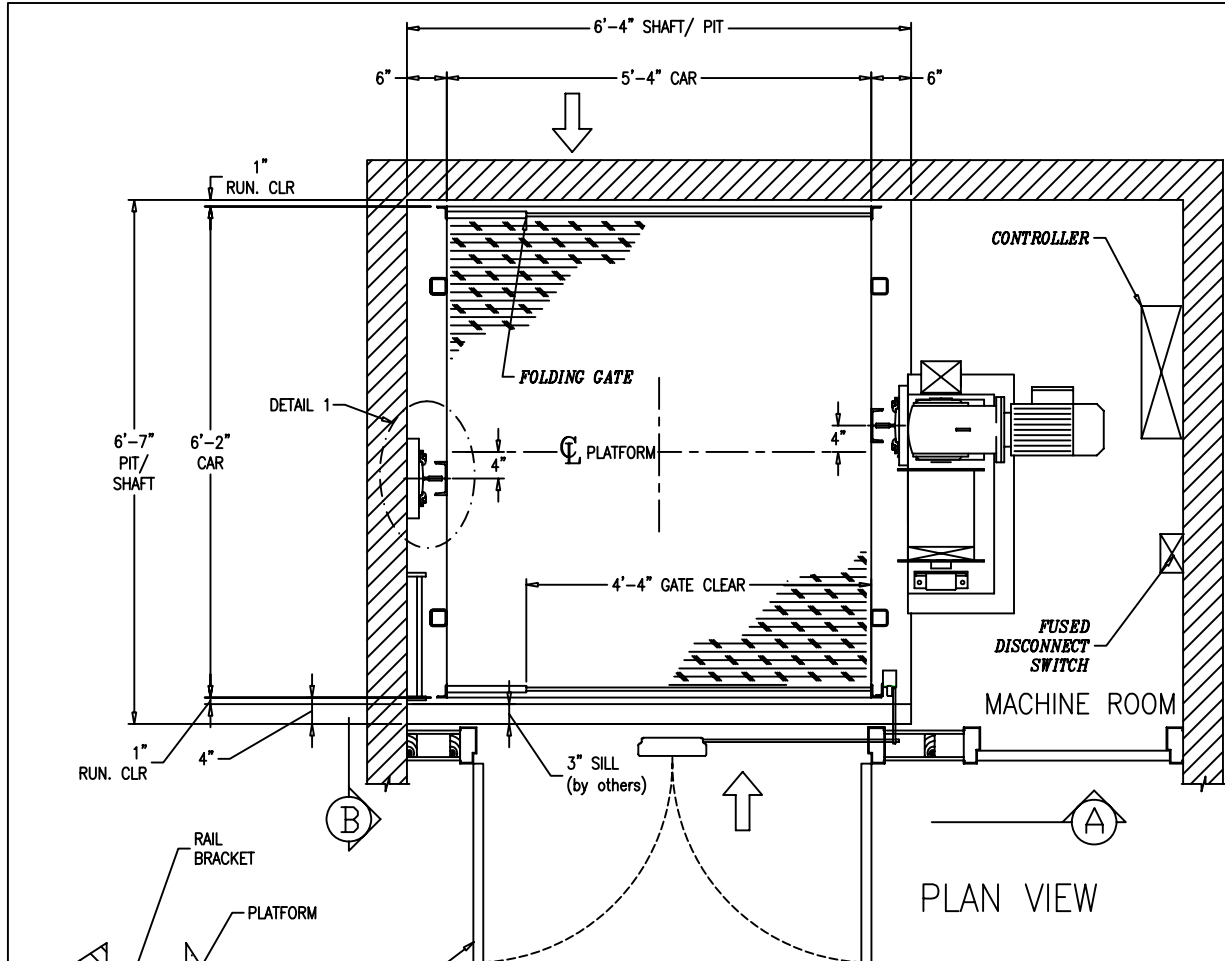

DETAIL 1

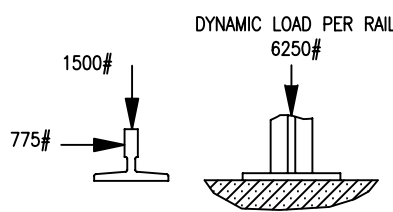
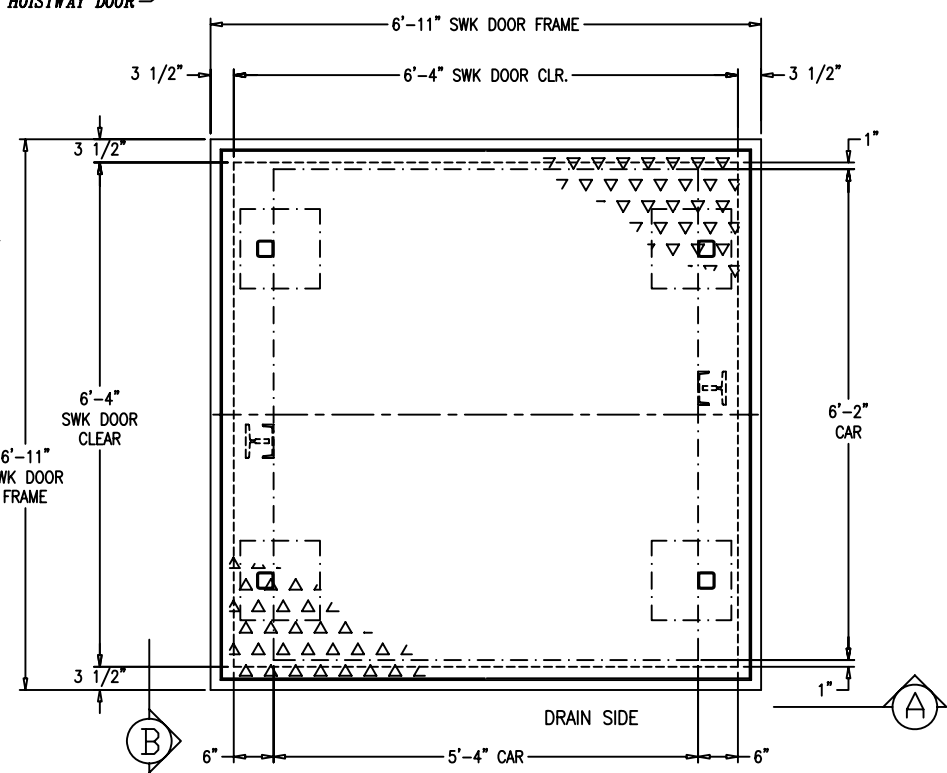

RAIL REACTIONS

**GILCO SIDEWALK DOOR**  
 1/4" DIAMOND PATTERN DOOR PLATES.  
 VERTICAL LIFT-UP, GUIDED ON (4) STANCHIONS.  
 Ø1" NPT PIPE TAPPED HOLE FOR DRAIN.  
 PAINT: BLACK ASPHALTUM PAINT.

**GILLESPIE CORPORATION**  
 WARE, MASSACHUSETTS

BUILDING:	
LOCATION:	
ARCHITECT:	
INSTALLER:	

ENGINEER	YM	DATE
CHECK		FILE NAME 8815-2R2.dwg
SO NO	8815	SHEET 2 OF 2