

Gillespie Corporation FOUNDED IN 1923

34 PINE STREET; P.O. BOX 359 WARE, MA 01082-0359

TEL: 413/967-4980

FAX: 413/967-9534

WEBSITE: www.gillespiecorp.com

E-MAIL: sales@gillespiecorp.com

Vertical Reciprocating Conveyor (VRC)

Low Cost Lift

A Vertical Reciprocating Conveyor (VRC) moves materials in factories, warehouses, industrial plants, institutions, private residences or anywhere that products, supplies or personal items need to move from one level to another. VRC's are not elevators. In fact, they have their own national code (ANSI/ASME B20.1) and are specifically exempt from the national elevator code. VRC's provide fast, efficient, convenient and safe access to/from mezzanines, balconies, basements, and between levels in multiple story buildings. They can be installed for through-floor, interior or exterior/outdoor applications. The principal components of a VRC include guide columns, a car/platform and a mechanical or hydraulic actuating mechanism.

For additional information call, e-mail us or visit our website: www.gillespiecorp.com

- **Economical** - Simplified design minimizes installation labor.
- **Efficient** - Minimal hoistway space requirements for maximum platform size.
- **Simplified installation** - Very easy to install as we provide detailed installation instructions.
- **No special skills or tools required** - Requires only normal mechanical hand tools.
- **Pre-set rail spacing** - Eliminates time-consuming rail-to-rail setting.
- **Minimal building loads** - Balanced design transmits vertical loads to the floor, with minimal horizontal loads.
- **Flexible** - Platforms can be sized to fit any existing or obsolete shaftway, and for restrictive space in NEW construction.
- **Pit** - Minimal pit requirement or can ramp up to platform.
- **Standard Model** - PWE-H utilizes an overhead hoist.
- **Drum Machine** - Model PWE-1 utilizes a winding drum that can be mounted overhead or at any level. Ideal for low overhead situations.
- **Back Guided** - Model PWE-HBG has from one to three sided access.
- **Corner Post** - Model PWE-HCP has from one to four sided access.
- **Code compliant** - Unit complies with ANSI/ASME B20.1 Code for Vertical Reciprocating Conveyors and OSHA safety requirements.
- **Safety** - Instantaneous broken chain safeties meet or exceed code for "backstop device" per ANSI/ASME B20.1.
- **Load limiter** - prevents platform overloading.
- **Engineering drawings** - Every unit is analyzed and you are provided with approval drawings for review. Each unit shipped with drawings, installation and operation instructions and a maintenance manual.

BY GILLESPIE

- ELECTRIC CHAIN HOIST WITH MOTOR, REDUCER, BRAKE, FINAL UPPER & LOWER LIMIT SWITCH. NORMAL UPPER & LOWER LIMIT SWITCHES.
- (2) SURFACE MOUNTED KEY OPERATED CONSTANT PRESSURE PUSH BUTTON STATIONS "UP"/"DOWN", "IN-USE" LIGHT.
- (2) FIXED CAMS ON CAR.
- OPEN DOOR BUZZER.
- INSTANTANEOUS WEDGE TYPE BROKEN OR SLACK CHAIN SAFETY.
- 16 GA BACK & FRONT SIDES x 6'-0" HIGH.
- 16 GA REAR SIDE x 10'-0" HIGH.
- 1/4" DIAMOND PATTERN FLOOR PLATE.
- 15# T-RAILS AND ACCESSORIES.
- (1) VERTICAL LIFT UP GATE 4'-0" W x 6'-8" H CLEAR W/ 5'-0" HIGH WIRE MESH PANEL.
- (1) VERTICAL LIFT UP GATE 3'-7" W x 6'-8" H CLEAR W/ 5'-0" HIGH WIRE MESH PANEL.

PAINTING

ONE SHOP COAT BLACK PRIMER.

BY OTHERS

- WIRING AND CONDUIT.
- SHAFTWAY ENCLOSURE.
- HOISTWAY DOORS W/ DOOR INTERLOCKS.

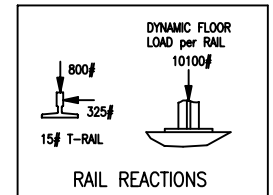

NOTE

RAIL & RAIL BRACKET LAYOUTS ARE SHOWN ON SHEET 2 OF 2 (SECTION C)

MODEL PWE-HCP

VERTICAL RECIPROCATING CONVEYOR
ANSI/ASME B20.1

DUTY(lbs) 3000 SPEED(fpm) 16
OUTPUT H.P. 4.7 VOLTAGE: 208/3/60

GILLESPIE CORPORATION
WARE, MASSACHUSETTS

JOB NAME: EXAMPLE ONLY

LOCATION: -

ARCHITECT: -

REPRESENTATIVE: -

CONTRACTOR: -

ENGINEER: YM CHECK

DATE: - FILE NO: 8602-1R2.dwg

SO NO: 8602 SHEET 1 OF 2

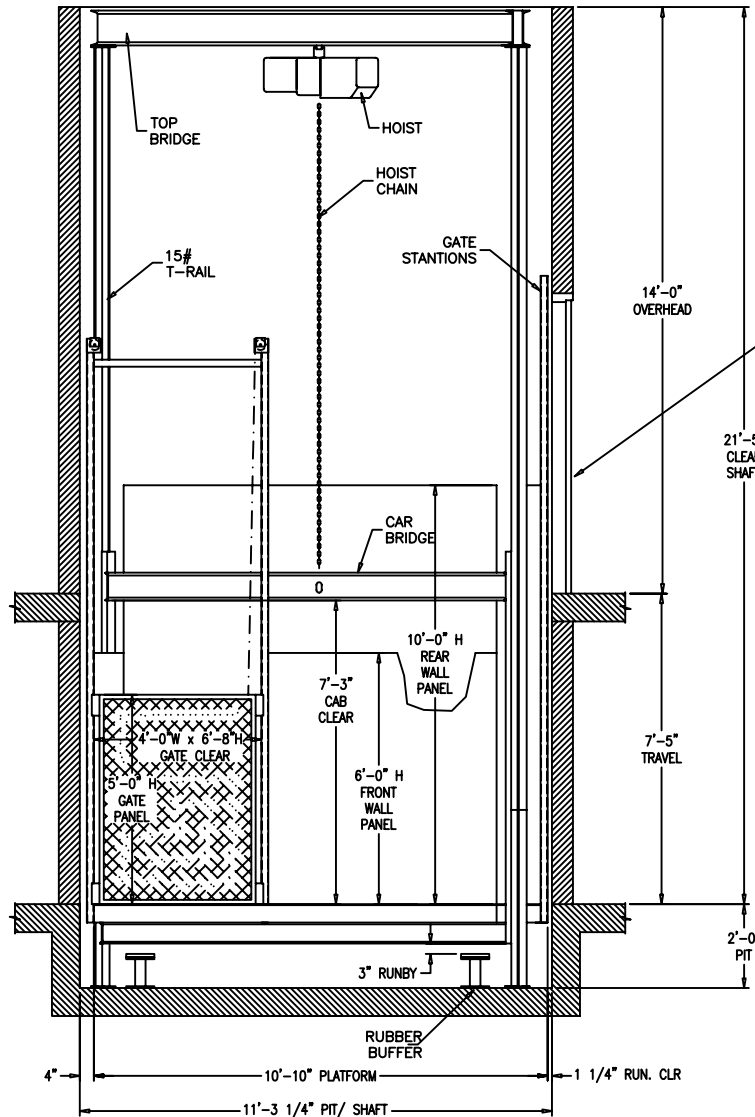

SECTION A

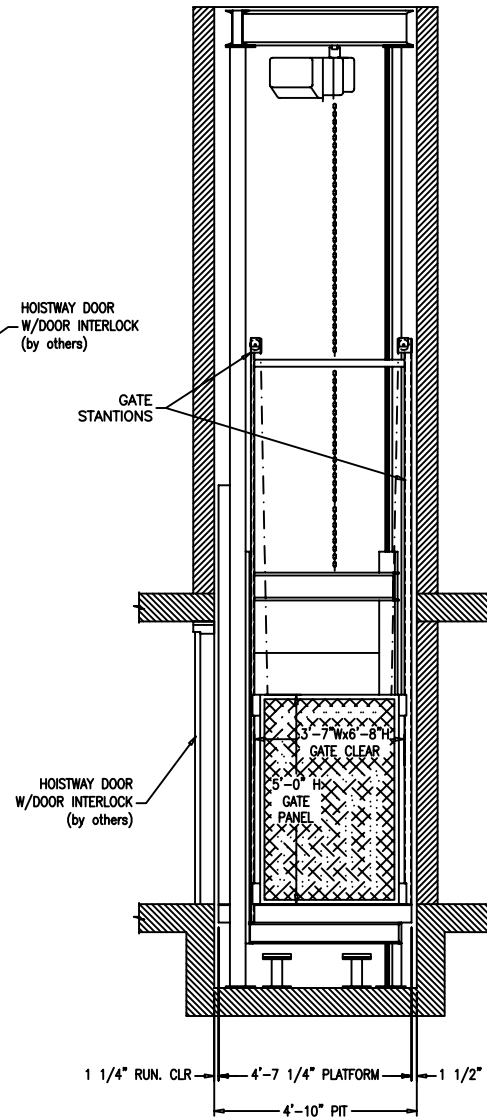

SECTION B

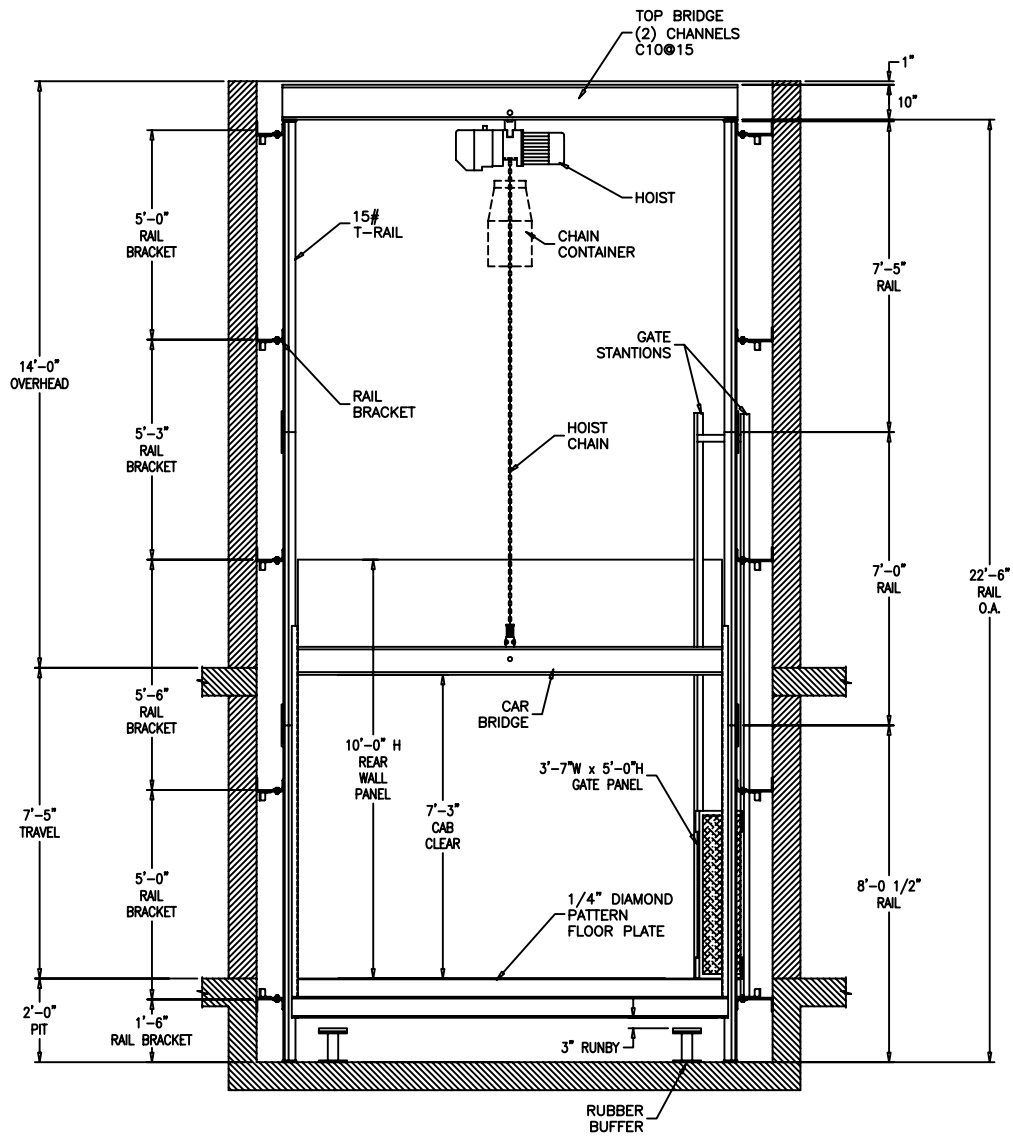

SECTION C

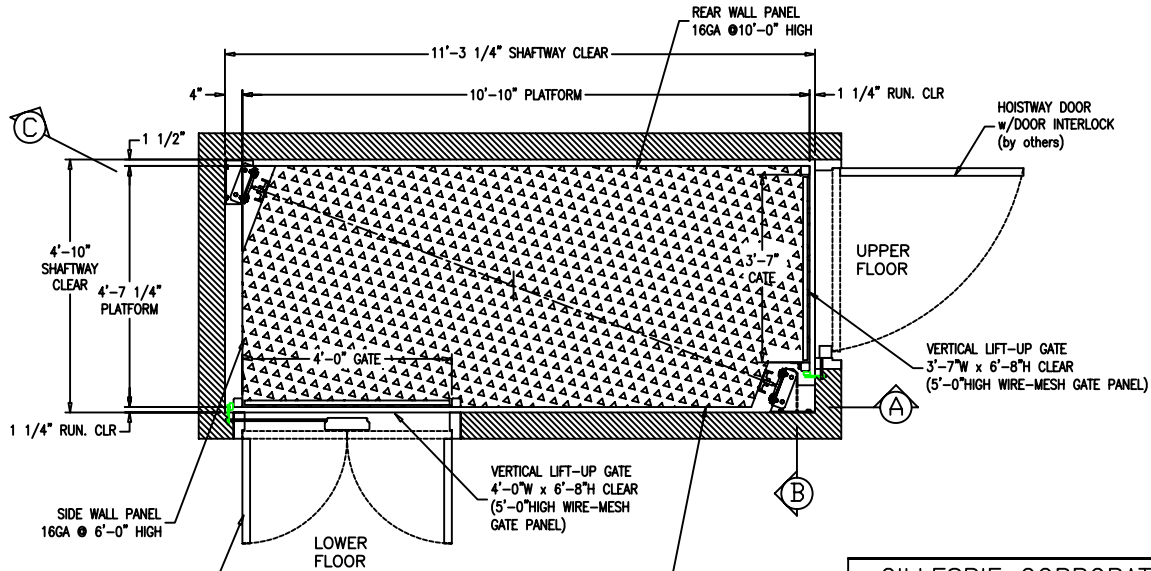

PLAN VIEW

GILLESPIE CORPORATION	
WARE, MASSACHUSETTS	
JOB NAME:	EXAMPLE ONLY
LOCATION:	-
ARCHITECT:	-
REPRESENTATIVE:	-
CONTRACTOR:	-
ENGINEER:	YM CHECK
DATE:	- FILE NO: 8602-2R2.dwg
SO NO: 8602	SHEET 2 OF 2